



ISG>PACK
AUTOMATIC PACKAGING SYSTEM

Nastratrici per scatole

CARTON SEALERS



EASY TAPE 50 TBB



Nastratrice semiautomatica a dimensionamento manuale con quattro cinghie di trascinamento motorizzate, due inferiori e due superiori. Questa macchina è particolarmente indicata per scatole alte e corte oppure instabili. Esegue la nastratura con nastro autoadesivo della parte inferiore e superiore di scatole a formato fisso di tipo americano. Il risultato è un perfetto allineamento delle falde e quindi una sigillatura ottimale, che viene effettuata dalle performanti teste nastranti. Corredata di rulliere in ingresso ed uscita, lama ferma scatole e ruote, costituisce una semplice e pratica postazione di imballaggio.



Semi-automatic manual dimensioning carton sealer with four feeding power belts, two top and two bottom. The machine tapes the top and bottom of American-type fixed size boxes with adhesive tape. This carton sealer is particularly suited for tall and short or unstable boxes. The result is a perfect alignment of box flaps and optimum sealing, performed by the efficient taping head. Machine is equipped with infeed and outfeed rollers, blade to stop the box and wheels, representing a practical and simple packaging station.



Macchine con dimensioni a richiesta
Customized machines on request



Presenza dell'operatore
With operator

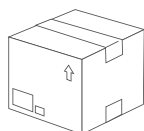

Nastratura superiore/inferiore
Top/bottom sealing

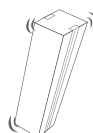

Cartoni instabili
Unstable cartons



Disponibile in acciaio Inox
Stainless steel version

EASY TAPE 50 TBB SS



PARTICOLARE TESTA NASTRANTE
DETAIL OF THE TAPING HEAD



INTERRUTTORE GENERALE
MAIN POWER SWITCH



RULLIERA INGRESSO SCATOLA
INFEED ROLLER CONVEYOR

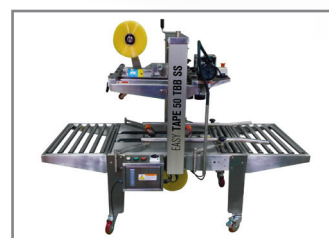

VERSIONE ACCIAIO INOX
STAINLESS STEEL VERSION

Caratteristiche tecniche

- ⊕ Peso: 100 Kg
- ⊕ Alimentazione elettrica: 220 Volts - 50 / 60 Hz
- ⊕ Velocità di trasferimento scatola: 20 mt / min
- ⊕ Peso max scatola: 30 Kg
- ⊕ Dimensioni macchina: L 1820 x W 920 x H 1490 - 1640 mm
- ⊕ Rumorosità max: ≤ 75 db
- ⊕ Fungo di emergenza per le normative CE
- ⊕ Nastro adesivo: Kraft, Polipropilene, PVC
- ⊕ Testa nastrante standard: 50 - 75 mm
- ⊕ Altezza piano lavoro: 600 - 750 mm

Technical details

- ⊕ Weight: 100 kg
- ⊕ Power supply: 220 Volts - 50 / 60 Hz
- ⊕ Box transfer speed: 20 mt / min
- ⊕ Maximum box weight: 30 kg
- ⊕ Machine dimensions: L 1820 x W 920 x H 1490 - 1640 mm
- ⊕ Maximum Noise: ≤ 75 db
- ⊕ Emergency stop in compliance with CE regulations
- ⊕ Adhesive tape: Kraft, Polypropylene, PVC
- ⊕ Standard taping head: 50 - 75 mm
- ⊕ Working table height: 600 - 750 mm

	DIMENSIONI SCATOLE BOX DIMENSION	
	MINIMO MIN	MASSIMO MAX
LUNGHEZZA LENGTH	150 mm	∞
LARGHEZZA WIDTH	150 mm	580 mm
ALTEZZA HEIGHT	120 mm	500 mm

	NASTRO ADESIVO ADHESIVE TAPE	
	TIPO TYPE	MASSIMO MAX
50 mm	PP PVC KRAFT	990 mt
75 mm	PP PVC KRAFT	990 mt
-	-	-

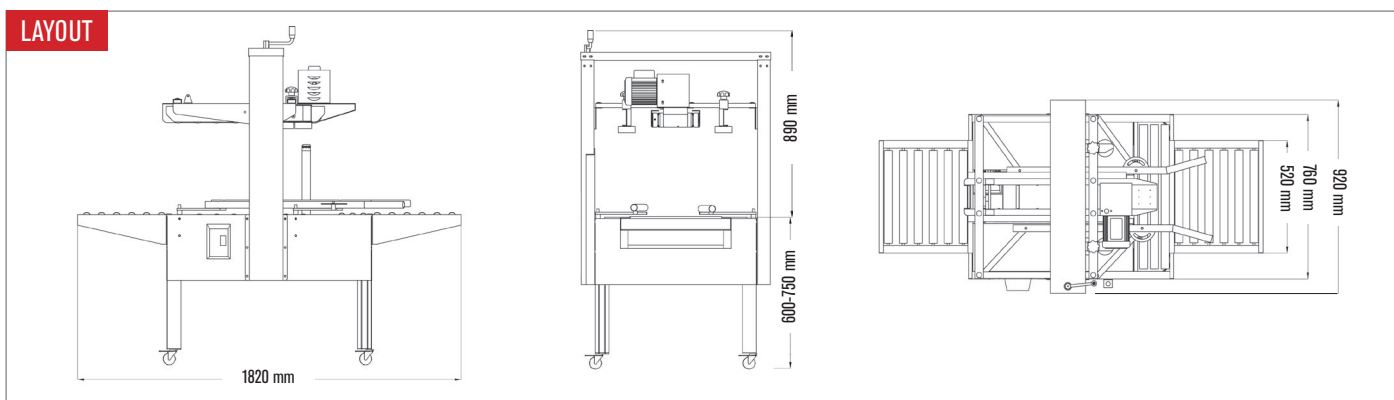

DATI TECNICI | DATA SHEET

Alimentazione elettrica | Power supply

220 volts - 1 ph - 50 / 60 Hz

Potenza Installata | Installed power

0,60 kW

Pressione aria | Air pressure

-

Consumo aria | Air consumption

-

Velocità nastratura | Sealing speed

Fino a 15 scatole min | Up to 15 boxes min

Testa nastrante | Taping head

50 - 75 mm

CARATTERISTICHE PRODOTTO LAVORABILE | PRODUCT FEATURES

Dimensioni min. scatole | Min box dimension

L 150 x W 150 x H 120 mm

Dimensioni max. scatole | Max box dimension

L ∞ x W 580 x H 500 mm

Tipologia di scatole | Box type

Scatole di tipo americano | American type boxes

ISG>PACK
AUTOMATIC PACKAGING SYSTEM

🌐 www.isg-pack.com @ info@imballaggiservice.com

Via Castelli Romani Km. 11,700 | Angolo Via Sassuolo, 6
00071 Pomezia | Roma | Italy
T. +39.06.9160.7561 | F. +39.06.9162.5014

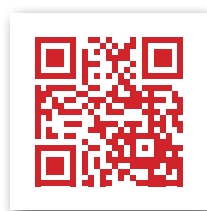

VISITA IL SITO WEB

