

OPTIONAL

TUNNEL FEEDING POWER

OPTIONAL

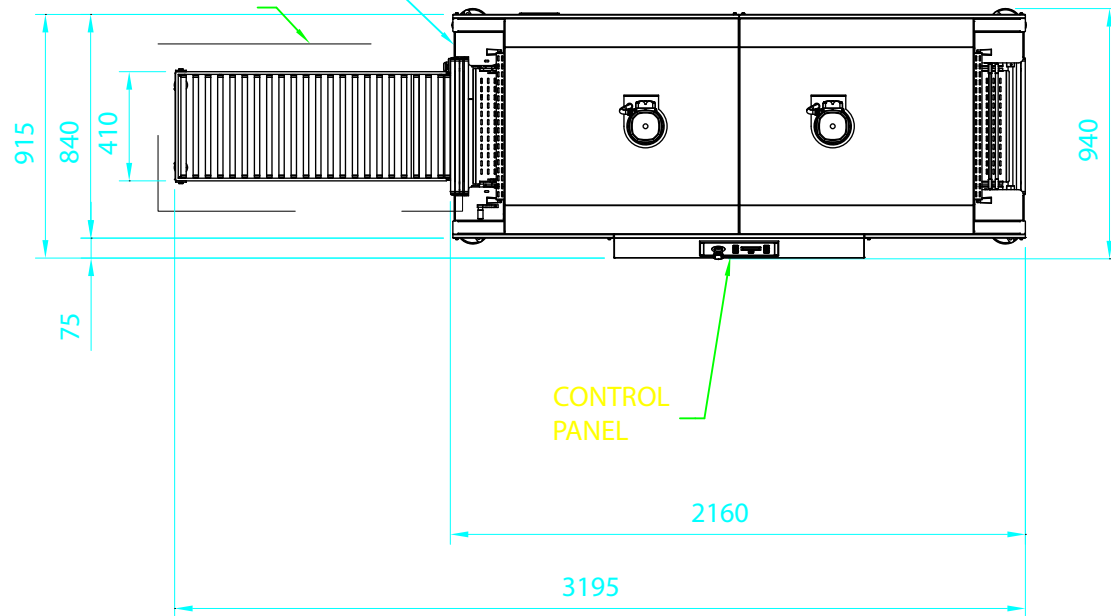

CONTROL PANEL

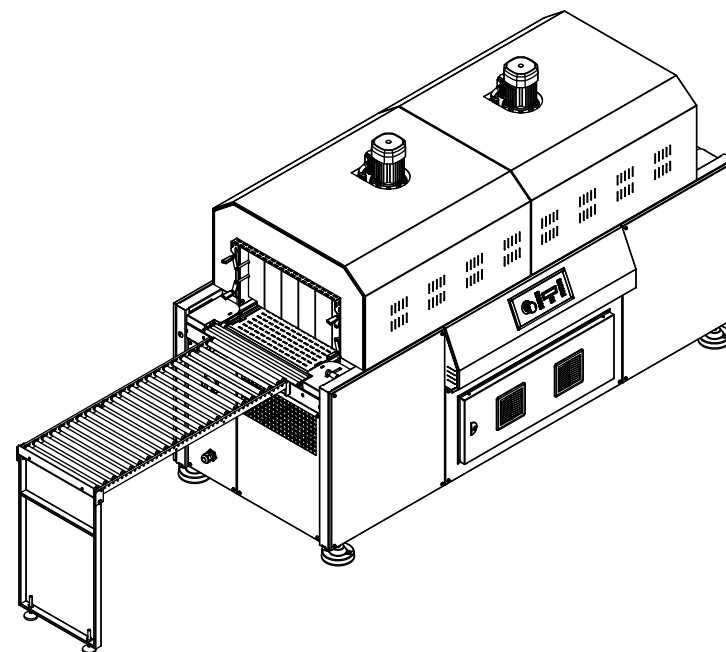

S55 DC HS

TECHNICAL SPECIFICATIONS

TOTAL WEIGHT	
POWER SUPPLY	380-415V 50-60 Hz 3PH + N + PE
	220-240V 50-60 Hz 3PH + PE
MACHINE INSTALLED POWER	W 12750

 <p>ISG Pack AUTOMATIC PACKAGING SYSTEM</p>	SCALA 1:20	DENOMINAZIONE LAYOUT S55 DC HS		FORMATO A3
	 DATA 29/05/2015 FIRMA	VISTO 29/05/2015	DISEGNO DL011010	FOGLIO 1/1 RF.MODIFICA