



ISG>PACK
AUTOMATIC PACKAGING SYSTEM

Nastratrici per scatole

CARTON SEALERS



MINI TAPE 50 SB



IT

Nastratrice semiautomatica a dimensionamento manuale, che sigilla con nastro autoadesivo la parte inferiore e superiore di scatole a formato fisso di tipo americano. La macchina può essere utilizzata da operatori non specializzati poiché richiede semplicissime operazioni di regolazione. Nasce per la nastratura di scatole di piccole dimensioni con un minimo di 95 mm di larghezza e 70 mm di altezza. L'avanzamento della scatola avviene mediante due cinghie laterali comandate da due motori, garantendo così la massima uniformità di scorrimento. Il risultato è un perfetto allineamento delle falde e quindi una sigillatura ottimale, che viene effettuata dalle performanti teste nastranti. Corredata di rulliere in ingresso ed in uscita, lama ferma scatole e ruote, costituisce una semplice e pratica postazione di imballaggio.

UK

Semi-automatic manual dimensioning carton sealer which seals the top and the bottom of American type fixed size boxes with adhesive tape. The machine can be used by non-specialized operator thanks to easy adjusting operations. Conceived for taping small boxes with a minimum height and width of 70 mm and 95 mm respectively. Box feeding is regulated by two lateral belts controlled by two motors and this system ensures maximum sliding uniformity. The result is a perfect alignment of the box flaps and optimum sealing, performed by the efficient taping head. Machine is equipped with infeed and outfeed rollers, blade to stop the box and wheels representing a practical and simple packaging station.

 **Macchine con dimensioni a richiesta**
Customized machines on request

 **Presenza dell'operatore**
With operator

 **Nastratura superiore/inferiore**
Top/bottom sealing

 **Cartoni piccoli**
Small cartons

 **Disponibile in acciaio Inox**
Stainless steel version
MINI TAPE 50 SB SS



INTERRUTTORE GENERALE
MAIN POWER SWITCH



PARTICOLARE TESTA NASTRANTE INFERIORE
DETAIL OF BOTTOM TAPING HEAD



RULLIERA INGRESSO/USCITA DI SERIE
INFEED/OUTFEED ROLLERS INCLUDED



REGOLAZIONE LARGHEZZA SCATOLA
BOX WIDTH ADJUSTMENT

Caratteristiche tecniche

- ⊕ Peso: 120 Kg
- ⊕ Alimentazione elettrica: 220 Volt - 50 / 60 Hz
- ⊕ Velocità di trasferimento scatola: 19 mt / min
- ⊕ Peso max scatola: 30 Kg
- ⊕ Dimensioni macchina: L 1976 × W 978 x H 1355 -1555 mm
- ⊕ Rumorosità max: ≤ 75 db
- ⊕ Fungo di emergenza per le normative CE
- ⊕ Nastro adesivo: Kraft, Polipropilene, PVC
- ⊕ Testa nastrante standard: 50 mm
- ⊕ Altezza piano lavoro: 550 - 750 mm

Technical details

- ⊕ Weight: 120 kg
- ⊕ Power supply: 220 Volt - 50 / 60 Hz
- ⊕ Box transfer speed: 19 mt / min
- ⊕ Maximum box weight: 30 kg
- ⊕ Machine dimensions: L 1976 × W 978 x H 1355 -1555 mm
- ⊕ Maximum Noise: ≤ 75 db
- ⊕ Emergency stop in compliance with CE regulations
- ⊕ Adhesive tape: Kraft, Polypropylene, PVC
- ⊕ Standard taping head : 50 mm
- ⊕ Working table height: 550 - 750 mm

	DIMENSIONI SCATOLE BOX DIMENSION	
	MINIMO MIN	MASSIMO MAX
LUNGHEZZA LENGTH	150 mm	∞
LARGHEZZA WIDTH	95 mm	500 mm
ALTEZZA HEIGHT	70 mm	500 mm

	NASTRO ADESIVO ADHESIVE TAPE	
	TIPO TYPE	MASSIMO MAX
50 mm	PP PVC KRAFT	990 mt
-	-	-
-	-	-

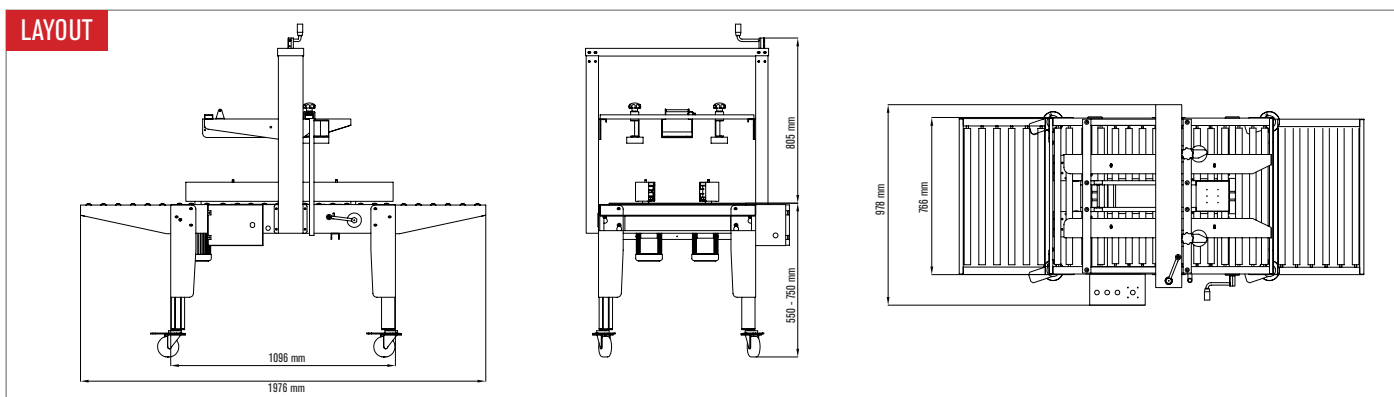

DATI TECNICI | DATA SHEET

Alimentazione elettrica | Power supply

Potenza Installata | Installed power

Pressione aria | Air pressure

Consumo aria | Air consumption

Velocità nastratura | Sealing speed

Testa nastrante | Taping head

MINI TAPE 50 SB

220 volts - 1 ph - 50 / 60 Hz

0,40 kW

-

-

Fino a 15 scatole min | Up to 15 boxes min

50 mm

CARATTERISTICHE PRODOTTO LAVORABILE | PRODUCT FEATURES

Dimensioni min scatole | Min box dimension

Dimensioni max scatole | Max box dimension

Tipologia di scatole | Box type

L 150 x W 95 x H 70 mm

L ∞ x W 500 x H 500 mm

Scatole di tipo americano | American type boxes

ISG>PACK
AUTOMATIC PACKAGING SYSTEM

🌐 www.isg-pack.com @ info@imballaggiservice.com

Via Castelli Romani Km. 11,700 | Angolo Via Sassuolo, 6
00071 Pomezia | Roma | Italy
T. +39.06.9160.7561 | F. +39.06.9162.5014

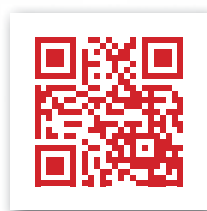

VISITA IL SITO WEB

